

8. MDD 090

8.1. Technical Data

Designation	Symbol	Unit	Motor type MDD ...		
			090 A-N-020	090 B-N-020	090 C-N-020
Nominal motor speed ¹⁾	n	min ⁻¹	2000	2000	2000
Continuous torque at standstill ²⁾	M_{dN}	Nm	3.7 (5.0) ⁵⁾	7.2 (10.5) ⁵⁾	10.4 (16.0) ⁵⁾
Continuous current at standstill	I_{dN}	A	4.0 (5.4) ⁵⁾	8.3 (12.2) ⁵⁾	12.1 (18.6) ⁵⁾
Theoretic maximum torque ³⁾	M_{max}	Nm	19.0	39.0	58.6
Maximum current	I_{max}	A	21.9	48.6	72.9
Moment of inertia of rotor ⁴⁾	J_M	kgm ²	20 x 10 ⁻⁴	36 x 10 ⁻⁴	53 x 10 ⁻⁴
Torque constant at 20 °C	K_m	Nm/A	0.93	0.86	0.86
Windings resistance at 20 °C	R_A	Ohm	6.84	1.99	1.20
Windings inductance	L_A	mH	27.7	10.1	6.8
Thermal time constante	T_{th}	min	45 (30) ⁵⁾	60 (45) ⁵⁾	60 (45) ⁵⁾
Mass ⁴⁾	m_M	kg	12.5	18	23
			090 A-N-030	090 B-N-030	090 C-N-030
Nominal motor speed ¹⁾	n	min ⁻¹	3000	3000	3000
Continuous torque at standstill ²⁾	M_{dN}	Nm	3.7 (5.0) ⁵⁾	7.2 (10.5) ⁵⁾	10.4 (16.0) ⁵⁾
Continuous current at standstill	I_{dN}	A	6.3 (8.5) ⁵⁾	12.6 (18.4) ⁵⁾	19.5 (30.0) ⁵⁾
Theoretic maximum torque ³⁾	M_{max}	Nm	17.7	38.9	56.3
Maximum current	I_{max}	A	32.2	72.9	117.8
Moment of inertia of rotor ⁴⁾	J_M	kgm ²	20 x 10 ⁻⁴	36 x 10 ⁻⁴	53 x 10 ⁻⁴
Torque constant at 20 °C	K_m	Nm/A	0.59	0.57	0.53
Windings resistance at 20 °C	R_A	Ohm	3.1	0.91	0.46
Windings inductance	L_A	mH	13.4	4.7	2.6
Thermal time constante	T_{th}	min	45 (30) ⁵⁾	60 (45) ⁵⁾	60 (45) ⁵⁾
Mass ⁴⁾	m_M	kg	12.5	18	23
			090 A-N-040	090 B-N-040	090 C-N-040
Nominal motor speed ¹⁾	n	min ⁻¹	4000	4000	4000
Continuous torque at standstill ²⁾	M_{dN}	Nm	3.7 (5.0) ⁵⁾	7.2 (10.5) ⁵⁾	10.4 (14.6) ⁵⁾
Continuous current at standstill	I_{dN}	A	9.4 (12.7) ⁵⁾	16.7 (24.3) ⁵⁾	24.4 (34.3) ⁵⁾
Theoretic maximum torque ³⁾	M_{max}	Nm	15.0	38.3	58.6
Maximum current	I_{max}	A	41.3	95.3	145.7
Moment of inertia of rotor ⁴⁾	J_M	kgm ²	20 x 10 ⁻⁴	36 x 10 ⁻⁴	53 x 10 ⁻⁴
Torque constant at 20 °C	K_m	Nm/A	0.39	0.43	0.43
Windings resistance at 20 °C	R_A	Ohm	1.30	0.50	0.29
Windings inductance	L_A	mH	14.5	2.6	1.6
Thermal time constante	T_{th}	min	45 (30) ⁵⁾	60 (45) ⁵⁾	60 (45) ⁵⁾
Mass ⁴⁾	m_M	kg	12.5	18	23

¹⁾ Usable motor speed is determined by the torque requirements of the application. The usable speed n_{max} found in the selection lists of the motor-drive combinations are binding for **standard applications**. The usable speed for other applications can be found using the required torque in the torque-speed characteristics curves

²⁾ With 60 K overtemperature at the motor housing.

³⁾ Achievable maximum torque is dependent upon the drive used. **Only** those maximum torques M_{max} found in the selection list of the motor-drive combinations are binding.

⁴⁾ Without blocking brake, without blower

⁵⁾ Parenthetical values apply to motors with surface cooling.

Fig 8.1: Type dependent motor data

Designation	Symbol	Unit	Data
Permissible ambient temperature	T_{um}	°C	0 ... + 45
Permissible storage and transport temperature	T_L	°C	-20 ... + 80
Maximum installation elevation		m	1000 meters above sea level
Protection category			IP 65
Insulation classification			F
Housing coat			Black prime coat (RAL 9005)

Fig 8.2: General data MDD 090

Designation	Symbol	Unit	Data Blocking Brake	
Principle of action			electrically actuated release	
Holding torque	M_H	Nm	6.5	11
Nominal voltage	U_N	V	DC 24 ± 10%	DC 24 ± 10%
Nominal current	I_N	A	0.5	0.5
Moment of inertia	J_B	kgm ²	1.06 x 10 ⁻⁴	1.06 x 10 ⁻⁴
Release delay	t_L	ms	60	60
Clamping delay	t_K	ms	20	20
Mass	m_B	kg	0.5	0.5

Fig 8.3: Technical data - blocking brake

8.4. Dimensional Data

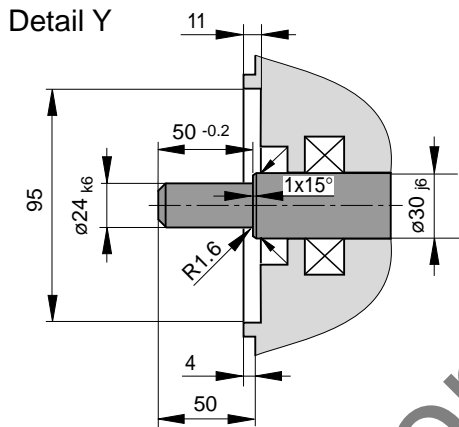
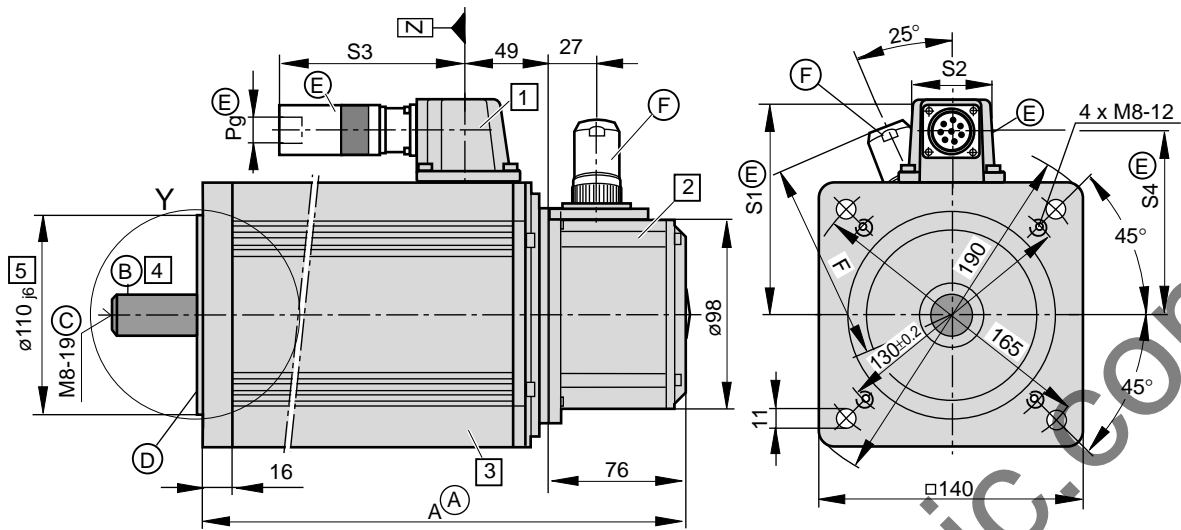

(A) Dimensional table Dim. A

Size	Dim. A 1)
MDD 090 A	275
MDD 090 B	340
MDD 090 C	405

1) Bigger with some options. The then applicable dimension is indicated with the respective feature.

(B) Concentricity, excentricity and coaxiality to the shaft per DIN 42955, tolerance class R, 12/81 edition.

- (C) • Shaft end per DIN 748 section 3, 7/75 edition, IEC 72, 1971 edition, cylindrical
- Center hole DS M3-8 per DIN 332 section 2, 5/83 edition
- Max. tightening torque M_A for screws in the threads of the center hole: 5 Nm
- Balance class N per DIN VDE 0530 section 14, 2/93 edition

- (D) Flange type per DIN 42948, 11/65 edition, makes mounting possible
 - as per design B5 (throughholes in flange)
 - as per design B14 (threads in flange)

- (E) **Motor power connector**
Depends on the motor, must be ordered separately.

Table of dimensions

type \ dim.	S1	S2	S3	S4	Pg
INS 252 2)	110	42	130	95	13,5
INS 108 3)	125	45	110	105	21

2) with MDD 090 A-N-020, MDD 090 A-N-030, MDD 090 A-N-040, MDD 090 B-N-020
3) other MDD 090

- (F) **Feedback connector**
Must be ordered separately.

Table of dimensions

Name	Connector type	Dim. F
straight conn.	INS 513	110
	INS 512	112
angle conn.	INS 511	108
	INS 510	

MBMDD090_1

Fig 8.9: Dimensional data - MDD 090

Available Options

1 Power connection

The output direction of the electrical power connector is selected at the time the order is placed. Possible output direction is either:

- side A or
- side B
- to the right
- to the left

The drawing depicts side A as output direction. The dimensions of any other output direction are obtained by virtually turning the connector housing around the Z axis.

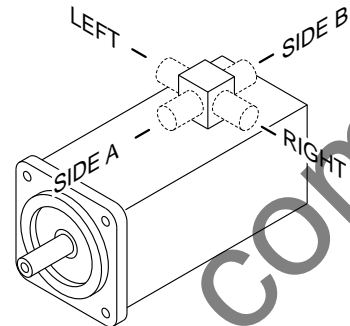

2 Motor feedback

- Digital servo feedback (DSF)
- Digital servo feedback (DSF) with integrated multiturn absolute encoder

The dimensions are identical.

3 Blocking brake

- without blocking brake
- with blocking brake: 6.5 Nm
- with blocking brake: 11 Nm

The dimensions are identical.

4 Output shaft

- plain shaft (preferred type)
- with keyway per DIN 6885 sheet 1, 8/68 edition
(Note: balanced with entire key!)

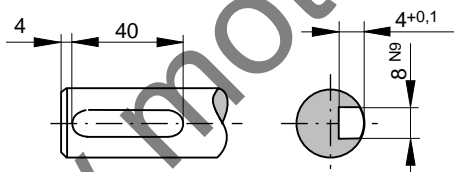

Matching key: DIN 6885-A 8 x 7 x 40

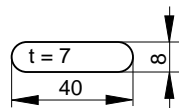

5 Special centering diameter

- $\varnothing 130_{j6}$

MBMDD090_2

Fig 8.10: Dimensional data - MDD 090 -available options

8.5. Available Versions

Type code field:	Example:	MDD	090	B	N	020	N	2	L	110	G	B	0
1. Name Motor for digital drive controllers	MDD												
2. Motor size	090												
3. Motor length	A, B, C												
4. Housing design: Standard (suited for natural convection and surface-cooling)	N												
5. Nominal speed 2000 min ⁻¹ 3000 min ⁻¹ 4000 min ⁻¹	020 030 040												
6. Balance class Standard (R per DIN VDE 0530 section 14, 2/93 edition)	N												
7. Side B shaft end Standard (without side B shaft end)	2												
8. Motor feedback digital servo feedback digital servo feedback with integrated multiturn absolute encoder	L M												
9. Centering diameter ø110 mm (Standard) ø130 mm	110 130												
10. Output shaft plain shaft shaft with keyway per DIN 6885 sh. 1, 8/68 edition	G P												
11. Power connection connector to side A connector to side B connector to the right (looking onto motor shaft, connecting housing at top) connector to the left (looking onto motor shaft, connecting housing at top)	A B R L												
12. Blocking brake without blocking brake with 6.5 Nm blocking brake with 11.0 Nm blocking brake	0 1 2												

Quelle: INN 41.60 TLMD090

Fig 8.11: Type codes - MDD 090